

HNPS Advances in Nuclear Physics

Vol 29 (2023)

HNPS2022

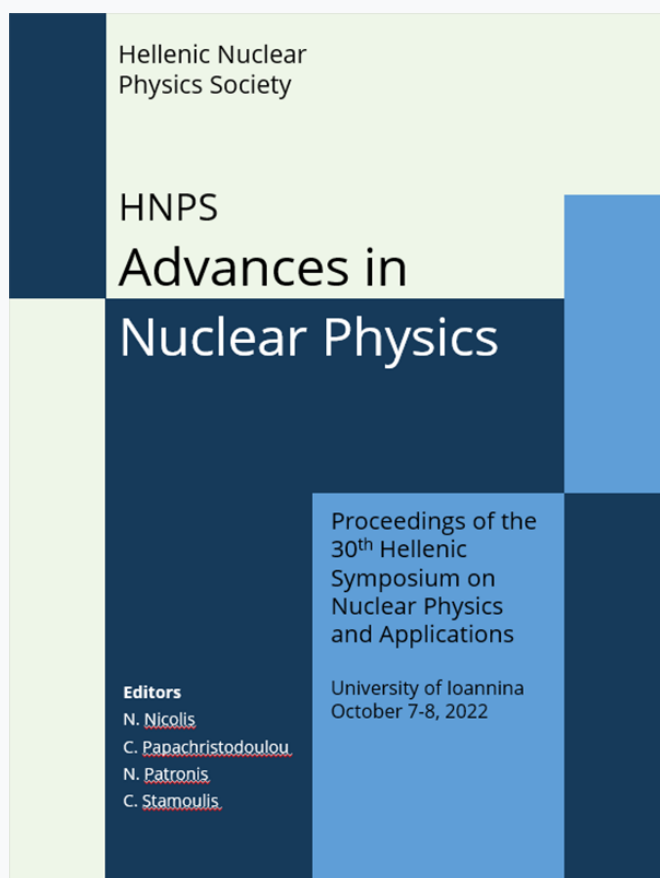

Study of HPGe detector shielding for use in inelastic neutron scattering experiments at the n_TOF/CERN facility

Dimitris Papanikolaou

doi: [10.12681/hnpsanp.5153](https://doi.org/10.12681/hnpsanp.5153)

Copyright © 2023, Dimitris Papanikolaou



This work is licensed under a [Creative Commons Attribution-NonCommercial-NoDerivatives 4.0](https://creativecommons.org/licenses/by-nc-nd/4.0/).

To cite this article:

Papanikolaou, D. (2023). Study of HPGe detector shielding for use in inelastic neutron scattering experiments at the n_TOF/CERN facility. *HNPS Advances in Nuclear Physics*, 29, 187–190. <https://doi.org/10.12681/hnpsanp.5153>

Study of HPGe detector shielding for use in inelastic neutron scattering experiments at the n_TOF/CERN facility

D. Papanikolaou^{1*}, M.E. Stamati^{1,2}, N. Patronis^{1,2}

¹University of Ioannina, Greece

²European Organization for Nuclear Research (CERN), Switzerland

Abstract The study of inelastic scattering reactions is important, both in basic research as it can provide an insight on nuclear structure and aid in the validation of theoretical models, as well as in the field of applications. The most frequently used method to determine the neutron induced inelastic scattering cross section is by recording the emitted gamma rays from the de-excitation of the target nucleus. In this direction, the high energy resolution of the HPGe detectors is instrumental. The experimental setup can be further improved by shielding the HPGe against the scattered neutrons. The purpose of this work is to investigate the contribution of such shieldings used in inelastic neutron scattering experiments at the n_TOF facility at CERN and to optimise the experimental set-up. In this study, GEANT4, a package for simulating the transport of radiation through matter, was used to study the effect of the various shielding materials and geometries for CANBERRA's EGPC 25S/N 540 p-type coaxial prototype HPGe.

Keywords Inelastic neutron scattering, HPGe detector, Shieldings, GEANT4

INTRODUCTION

Neutron inelastic scattering cross section data play a significant role in a variety of fields, ranging from basic nuclear research to nuclear technology, such as new generation nuclear power reactors and shielding applications. An inelastic scattering reaction is followed by the emission of γ -rays, when the residual nucleus decays to its ground state. The production cross section of these γ -rays can lead to the total inelastic cross section or give it some lower and upper bounds. It is thus important to have many and well evaluated data sets, covering as wide an energy range as possible.

The n_TOF facility at CERN is a facility designed to study neutron induced reactions. It is based on a spallation source, where neutrons are produced when a pulsed proton beam from CERN's PS accelerator impinges on a lead target. The resulting neutron energy spectrum is very wide, stretching from the meV to the GeV region, with the exact energy of the neutrons being determined via time-of-flight (TOF) technique. A typical experiment is performed by placing a sample in the neutron beam, with one or more detectors around it to measure the products of the reaction. In the case of inelastic scattering, a measurement can be performed by detecting the γ -rays emitted during the de-excitation of the target nucleus after the reaction. Many such measurements using γ -ray spectroscopy have been performed in the past and at various facilities, providing qualitative data with low uncertainties [1-3]. This work aims at the optimisation of a γ -ray spectroscopy set-up based on a HPGe detector at the n_TOF facility at CERN.

In order to investigate and validate the optimisation of the experimental set-up, this feasibility study was based on simulating the response of a HPGe detector to two reactions, $^{56}\text{Fe}(n,n')$ and $^7\text{Li}(n,n')$, for different choices of set-up geometry and shielding material. Concerning the choice of the first reaction under study, iron is a widely used material in mechanical components as it is one of the primary structural materials of nuclear reactors and thus its nuclear properties have, for example, a significant impact on neutron transport calculations in steel reflectors of nuclear reactors. In the case of lithium fluoride (LiF), it has been proposed as a reference for other γ -ray production cross-section

* Corresponding author: dimitrpapanik@gmail.com

measurements, in the energy range 0.8 - 8 MeV, thus it is well suited for the validation of new detection systems for (n,n') measurements. A second reason comes from the fact that there is enough experimental information available already and a "proof of principle" study can practically be based on these reactions. The simulation toolkit employed for this study was GEANT4.

EXPERIMENTAL DETAILS

In TOF facilities, it is most common to place the detectors at backward angles so as to minimise their exposure to the γ -flash, a term used to describe the relativistic particles and photons produced along with the neutron beam. This causes a large amount of energy to be deposited in the detector, even before the neutron beam reaches the sample and the reactions of interest begin to take place. It has been shown both by experimental tests and simulations that the effect of the γ -flash on the detector is minimised if the detector is placed at a backward angle [4,5]. For this reason, in all the simulations of this study, the detector volume was placed at an angle of 125° relative to the beam. The distance between the detector window and the sample was a free parameter.

At the n_TOF facility, data are recorded in the form of movies, as the amplitude of the detector signal is a function of time. Since the number of counts recorded at any given time is very large, the signals overlap with each other making it difficult to analyse them and it is necessary to use shieldings that reduce, up to a point, the number of counts and smoothen the averaged curve of movies, thus increasing their recording clarity. For this study, two shielding materials were investigated: polyethylene (PE) and JC215 (PE + lithium). Polyethylene, a material rich in hydrogen, is commonly used in neutron moderation, while Li has a high neutron capture cross section, aiding the absorption of thermal neutrons. The shape of the PE shielding was cubic, while for the JC215, an already existing at n_TOF hemispherical piece was introduced in the simulation. Furthermore, specifically for the case of the LiF sample, a thin lead (Pb) sheet was also added to the set-up, in order to cut off γ -rays originating from the de-excitation of the 1st excited state of fluorine, following inelastic scattering reactions. Such a sheet does not significantly compromise the measurement of the γ -rays of interest, as they are of higher energy compared to the ones coming from the decay of fluorine. In Figure 1, a visualisation of the set-up can be seen: the case of the JC215 shielding in Fig. 1a, the case of a PE shielding in Fig. 1b and the addition of a lead sheet to the latter in Fig. 1c.

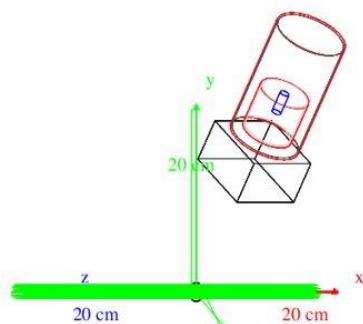

Figure 1a: Iron target with PE Shielding

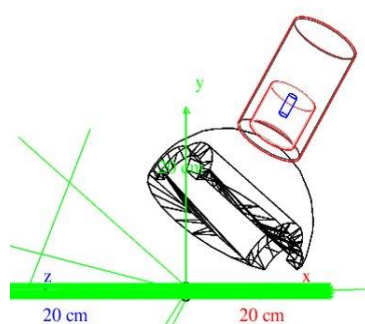

Figure 1b: Iron target with JC215 Shielding

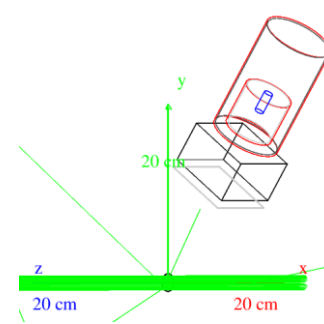

Figure 1c: LiF target with PE Shielding & Pb sheet in front

RESULTS AND DISCUSSION

The methodology of this study was to simulate the response of the HPGe detector to one pulse and record the energy deposited in the detector as a function of time to form a simulated movie. Since the energy deposited in the detector for each pulse is a stochastic process, many movies were simulated and then averaged, in order to draw reliable conclusions. The qualitative and quantitative results of the above procedure are discussed below.

The first parameter to be determined was the detector-target distance. Based on a compromise between the minimum value necessary to place the shielding in such a way that it does not interact with the beam halo and yet maintaining satisfactory statistics, the value of 20 cm was chosen for the rest of the study.

Case of ^{56}Fe sample

In the case of iron, the PE and JC215 shieldings have similar results: the number of background counts is greatly decreased and the curve of the movie is remarkably smoothed (Fig. 2). The number of counts recorded in the photopeak of interest (0.8468 MeV) is also decreased by a factor 2 (Fig. 3), a factor that can be compensated, however, with an increase in measuring time. Seeing how both materials give equally satisfactory results, JC215 is preferred due to its advantage of containing Li that can absorb thermal neutrons and the fact that it is already machined and available.

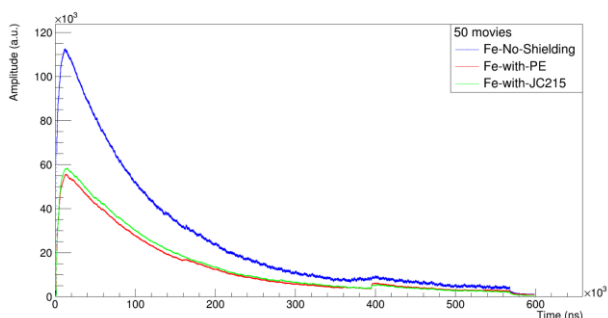

Figure 2: Averaged curve of 50 movies for ^{56}Fe . Without shielding (blue), with PE (red) with JC215 (green)

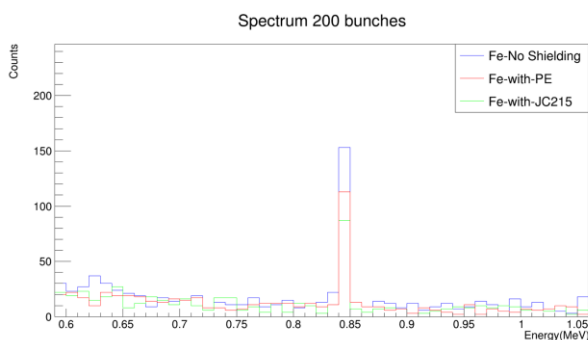

Figure 3: ^{56}Fe spectrum for 200 bunches and 1mm sample thickness. Without shielding (blue), with PE (red) with JC215 (green)

Case of LIF sample

In the case of lithium, JC215 is not anymore a viable shielding option, as it contains lithium and can interfere with the measurement. A PE shielding has satisfactory results in the reduction of counts recorded in the detector (Fig. 4). Another factor that has to be taken into account in the lithium case is that the sample also contains fluorine, which becomes another source of background, as neutrons can be captured by it. To reduce the resulting emitted γ -rays, a lead foil of varying thickness is introduced in the simulation. It can be observed that the thinner foil reduces the number of counts recorded in the fluorine peaks to a satisfactory degree, while leaving the lithium peak even more unaffected (Fig. 5). A result which we expected, as the fluorine peaks are lower in energy so they are more easily absorbed by a thinner lead sheet, thus not compromising statistical accuracy in the peaks of interest.

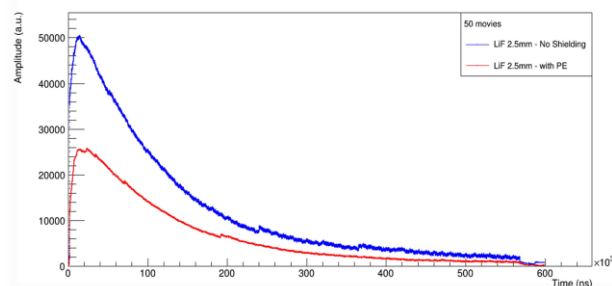

Figure 4: Averaged curve of 50 movies for LiF, with (red) and without shielding (blue)

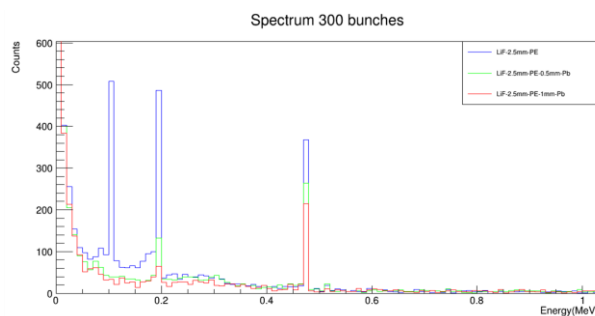

Figure 5: LiF spectrum for 300 bunches and 2.5mm target thickness. With PE (blue) & 2 different thickness Pb sheets (green – 0.5mm, red - 1mm)

CONCLUSIONS

In this work, the contribution of two shielding materials to a neutron inelastic scattering measurement setup was investigated through simulations with the GEANT4 simulation software. The setup consists of an HPGe detector placed at 125° relative to the beam and the study employed two reactions, $^{56}\text{Fe}(n,n')$ and $^7\text{Li}(n,n')$. The aim was to optimise the experimental set-up by minimising the number of unwanted signals recorded in the detector through the use of proper shielding. For the first of the two reactions, a hemispherical piece of JC215 (PE+Li) was selected as the optimal option, while for the second one, a cubic piece of PE. Additionally, the inclusion of a 0.5 mm Pb sheet before the PE block can further optimise the set-up by absorbing γ -rays emitted after the capture of neutrons by the fluorine of the LiF sample.

References

- [1] L.C. Mihailescu, L. Oláh, C. Borcea, A.J.M. Plompen, Nucl. Instrum. Meth. Phys. Res. A 531, 375 (2004)
- [2] L.C. Mihailescu, C. Borcea, A. Koning, A.J.M. Plompen, Nucl. Phys. A 786, 1 (2007)
- [3] L.C. Mihailescu, C. Borcea, *et al.*, Nucl. Phys. A 811, 1 (2008)
- [4] M.E. Stamati, Master's thesis, University of Ioannina Ioannina, Greece (2020)
- [5] C. Petrone, Detector Kick-Off Meeting presentation, CERN, 10/04/2019