

HNPS Advances in Nuclear Physics

Vol 15 (2006)

HNPS2006

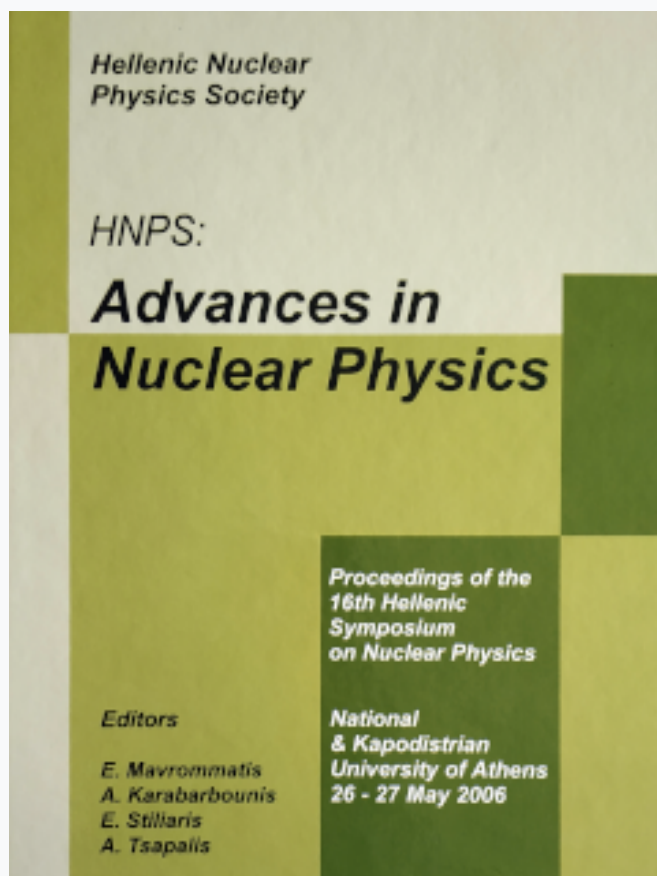

**DISTRIBUTION OF MAXIMA OF THE
ANTISYMMETRIZED WAVE FUNCTION FOR THE
NUCLEONS OF A CLOSED-SHELL AND FOR THE
NUCLEONS OF ALL CLOSED-SHELLS IN A
NUCLEUS.**

G. S. Anagnostatos

doi: [10.12681/hnps.2620](https://doi.org/10.12681/hnps.2620)

To cite this article:

Anagnostatos, G. S. (2020). DISTRIBUTION OF MAXIMA OF THE ANTISYMMETRIZED WAVE FUNCTION FOR THE NUCLEONS OF A CLOSED-SHELL AND FOR THE NUCLEONS OF ALL CLOSED-SHELLS IN A NUCLEUS. *HNPS Advances in Nuclear Physics*, 15, 57–66. <https://doi.org/10.12681/hnps.2620>

**DISTRIBUTION OF MAXIMA OF THE ANTISYMMETRIZED WAVE FUNCTION
FOR THE NUCLEONS OF A CLOSED-SHELL AND
FOR THE NUCLEONS OF ALL CLOSED-SHELLS IN A NUCLEUS.**

GERASIMOS.S. ANAGNOSTATOS,
*Institute of Nuclear Physics,
National Center for Scientific Research Demokritos,
Aghia Paraskevi, Attiki, 15310 Greece
e-mail: anagnos4@otenet.gr
Telephone/fax: ++(30) (210) 6659278*

Abstract

The significant features of exchange symmetry are displayed by simple systems such as two identical, spinless fermions in a one-dimensional well with infinite walls. The conclusion is that the maxima of probability of the antisymmetrized wave function of these two fermions lie at the same positions as if a repulsive force (of unknown nature) was applied between these two fermions. This conclusion is combined with the solution of a mathematical problem dealing with the equilibrium of identical repulsive particles (of one or two kinds) on one or more spheres like neutrons and protons on nuclear shells. Such particles are at equilibrium only for specific numbers of particles and, in addition, if these particles lie on the vertices of regular polyhedra or their derivative polyhedra. Finally, this result leads to a pictorial representation of the structure of all closed shell nuclei. This representation could be used as a laboratory for determining nuclear properties and corresponding wave functions.

Keywords: many fermion system, equilibrium polyhedra, closed shells, magic numbers.

1. Introduction

In this work we search for the distribution of maxima of the antisymmetric wave function of many fermions, specifically, of the nucleons of a nuclear shell or of the nucleons of all closed shells in a nucleus, without a precise knowledge of the wave function.

This effort is materialized by strictly following the consequences of the nature of the particles involved, i.e., the fermionic nature of nucleons.

Apparently, this is a many-body problem in its specific case where the particles are fermions and where their quantity is more than a few (i.e., it is not a few-body problem) and where the fermion quantity is not so high as in a solid body (i.e., it is not an excessive number of particles problem). In other words, it is a **mesoscopic** physics problem.

As known, as a many-body problem could be considered any problem with any number of particles more than one. Specifically, in this work we start with the simplest possible problem considering the very specific case of two identical fermions in one-dimensional square-well potential with infinite walls. Afterwards, we extend the research to the number of identical nucleons of a closed shell and to the number of identical nucleons of all closed shells in a nucleus by taking advantage of the conclusions of the above elementary problem of two identical spinless fermions together with the solutions of a well-analyzed relevant mathematical problem.

2. The nuclear Hamiltonian

As a first step of this work we analyze the nuclear Hamiltonian into partial Hamiltonians one per nuclear shell and different for protons and neutrons as follows

$$H = {}_pH_{1s} + {}_pH_{1p} + {}_pH_{1d2s} + \dots \\ + {}_nH_{1s} + {}_nH_{1p} + {}_nH_{1d2s} + \dots \quad (1)$$

In the following first we search for the maxima of probability of the antisymmetric wave function for the identical nucleons for each nuclear shell and then for the nucleons of all shells in a closed-shell nucleus. As a first step we examine the simplest possible problem described below.

After the above search of maxima is completed, we can go backwards to determine explicitly the relevant Hamiltonian in Eq.(1) and the corresponding wave functions as suggested at the end of this work.

3. Two identical fermions in a square well potential with infinite walls.

The total energy for two non-interacting spinless fermions is

$$-(\hbar^2/2m) (\partial^2\Psi/\partial x_1^2) - (\hbar^2/2m) (\partial^2\Psi/\partial x_2^2) + V_1(x_1)\Psi + V_2(x_2)\Psi = (\hbar/i)\partial\Psi/\partial t \quad (2)$$

where $V_1(x_1) = 0$ for $0 \leq x_1 \leq L$ and ∞ elsewhere

$V_2(x_2) = 0$ for $0 \leq x_2 \leq L$ and ∞ elsewhere and

$$\Psi = \Psi(x_1, x_2, t)$$

Equation (2) is separable in its three variables and the two coordinate-dependent equations are

$$d^2\psi_1/dx_1^2 + (2m/\hbar^2)[W_1 - V_1(x_1)] \psi_1 = 0 \quad (3)$$

$$d^2\psi_2/dx_2^2 + (2m/\hbar^2)[W_2 - V_2(x_2)] \psi_2 = 0 \quad (4)$$

where

$$W = W_1 + W_2 = \hbar^2 n^2 \pi^2 / 2mL^2 + \hbar^2 k^2 \pi^2 / 2mL^2 \quad (5)$$

$n = 1, 2, 3, \dots$ and $k = 1, 2, 3, \dots$

The one-particle eigenfunctions are

$$\Psi_1(\chi_1) = \sqrt{2}/L \sin(n\pi x_1/L) \text{ and} \quad (6)$$

$$\Psi_2(\chi_2) = \sqrt{2}/L \sin(k\pi x_2/L) \quad (7)$$

and the two-particle eigenfunctions are

$$\Psi_1^0(\chi_1, \chi_2) = (2/L) \sin(n\pi x_1/L) \sin(k\pi x_2/L) \text{ and} \quad (8)$$

$$\psi_2^0(\chi_1, \chi_2) = (2/L) \sin(n\pi x_2/L) \sin(k\pi x_1/L) \quad (9)$$

These wave functions are apparently degenerate if $n \neq k$. This degeneracy is due to the symmetry with respect to the interchange of the two identical fermions. If, however, there is some mutual interaction between the two identical fermions in the form of some mutual potential energy $H'(x_1, x_2)$ which is unchanged in sign and magnitude upon the interchange of x_1 and x_2 , then there are only the following two possible choices for the zero-order wave function for the two fermions system

Symmetric wave function:

$$\Psi_s = (1/\sqrt{2})(2/L)[\sin(n\pi x_1/L)\sin(k\pi x_2/L) + \sin(n\pi x_2/L)\sin(k\pi x_1/L)] \quad (10)$$

Antisymmetric wave function:

$$\Psi_a = (1/\sqrt{2})(2/L)[\sin(n\pi x_1/L)\sin(k\pi x_2/L) - \sin(n\pi x_2/L)\sin(k\pi x_1/L)] \quad (11)$$

The above results come from the following secular equation

$$\begin{pmatrix} (H'_{11} - W') & H'_{12} \\ H'_{21} & (H'_{12} - W') \end{pmatrix} = 0 \quad (12)$$

The determinant becomes

$$(H'_{11} - W')^2 = (H'_{12})^2, \quad (13)$$

since $H'_{12} = H'_{21}$,

$H'_{11} = H'_{22}$, given that

$$H'_{11} = \int \psi_1^0 * H' \psi_1^0 dx_1 dx_2, \text{ etc.}$$

In Fig.1 a plot of Eqs. (10 and 11) is shown, i.e., a plot for both symmetric [part (a) of the figure] and antisymmetric [part (b) of the figure] wave function of the system. The horizontal axis of the plot is used to mark positions inside the potential well from 0 to L for the particle assigned the number 1, likely the vertical axis for the particle assigned the number 2. In both parts of the figure the probability amplitudes are considered perpendicularly to the paper and are presented by counters numbered 1.0, 1.5, 2.0. As apparent from the figure the maxima of probability in the case of symmetric wave function lie on the shown broken line where both particles lie at $x_1 = x_2$, either at the position $x_1 = x_2 = L/4$ or at the position $x_1 = x_2 = 3L/4$, while in the case of antisymmetric wave function the maxima of probability lie out of this line and specifically the one at the position $L/4$ and the other at the position $3L/4$. This means that

for the symmetric wave function of the system the maxima of probability of the two particles coincide and the two particles are found together there, while for the antisymmetric wave function of the system the particles have zero probability of being together. This conclusion is equivalent to saying that among the particles, an attractive force was applied in the case of symmetric wave function and a repulsive force (of unknown nature) was applied in the case of antisymmetric wave function [1].

Thus, the antisymmetrization requirement of two identical fermions in a potential well results in a situation for the maxima of probability of these identical fermions equivalent to the situation we would have if among these two fermions a repulsive force (of unknown nature) was applied.

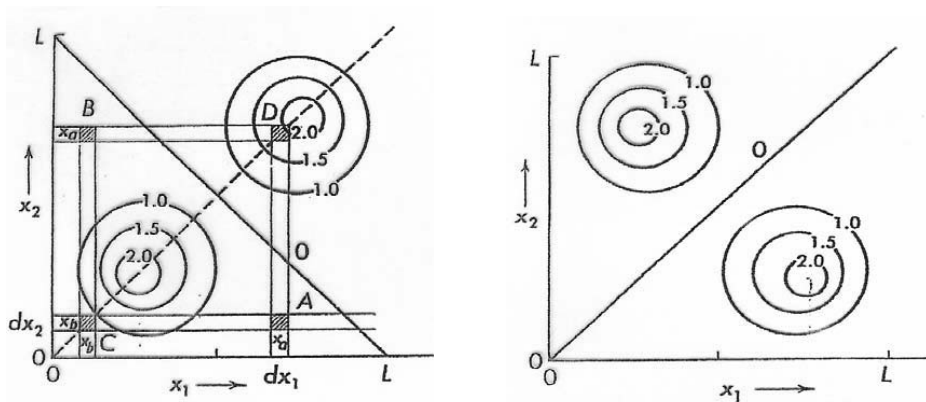

Fig.1. (a) Symmetric wave function: $\psi_s^* \psi_s$ with $n = 1$ and $k = 2$, according to Eq.(10), (b) Antisymmetric wave function: $\psi_a^* \psi_a$ with $n = 1$ and $k = 2$, according to Eq.(11).

4. Nucleons in a closed shell and in all shells of a closed-shell nucleus.

In the rest of this work we will take advantage of the above conclusion in order to proceed with the problem of the many nucleons of a nuclear shell or of the many nucleons of all shells in a closed-shell nucleus. In order to do so we extensively use the paper of Leech [2] dealing with the equilibrium of one or two kinds of repulsive nucleons on a sphere resembling the behavior of one or two kinds of identical fermions on a nuclear shell or shells.

According to this paper of Leech, repulsive particles on a sphere are at equilibrium (or at their positions of maximum probability) only for **specific numbers of particles** and if these particles lie on the vertices of one of the **regular polyhedra or of one of their derivative polyhedra or simultaneously of a regular polyhedron and one or two derivative polyhedra**. We call derivative polyhedra of a regular polyhedron those polyhedra which are derived by considering the middles of faces or the middles of edges of the initial polyhedron.

Figure 2 represents the Leech polyhedra in three rows. Vertical blocks in the first two rows of the figure represent reciprocal polyhedra, that is, polyhedra where the vertices of the one are the middles of faces of the other. The third row makes more apparent the relative orientation of the above reciprocal pairs for the special case where orthogonal edges of the reciprocal pairs of polyhedra bisect each other. At each block of the figure the number of

vertices of the relevant polyhedron is given in parentheses, while at the bottom of the block the official name and/or its mathematical abbreviation of this polyhedron is also given.

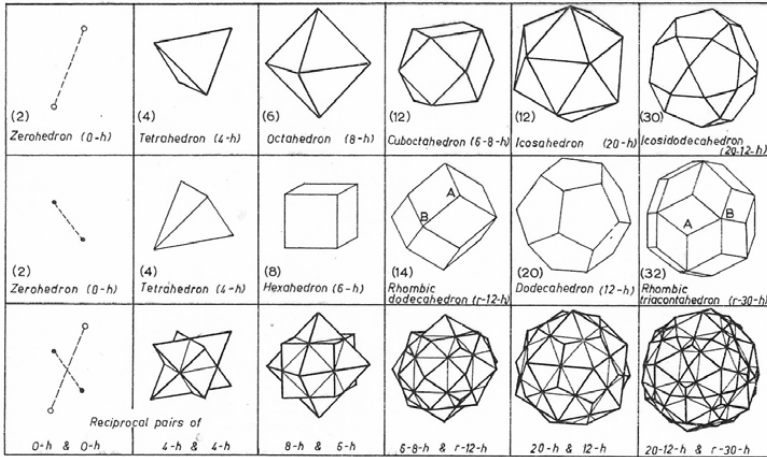

Fig.2. Leech-type equilibrium polyhedra.

The Leech paper as mentioned earlier, also deals also with the equilibrium of two categories of identical repulsive particles on spheres. The particles of each category are at equilibrium with themselves and in addition at equilibrium with the particles of the other category, which means that the equilibrium polyhedron of the one category should be reciprocal to the equilibrium polyhedron of the other category. Thus, here as two categories of identical repulsive particles, we have two categories of identical fermions as neutrons and protons on neutron and proton shells. The probability that these nucleons lie on the vertices of two reciprocal polyhedra is at a maximum. Thus, these polyhedra represent the most probable forms of a neutron and of a relevant proton shell. Two reciprocal polyhedra (e.g., a cube and an octahedron, or a dodecahedron and an icosahedron) have the same rotational symmetry, as expected for a proton shell and its relevant neutron shell, e.g., an 1p proton shell and its relevant 1p neutron shell or an 1d2s proton shell and its relevant 1d2s neutron shell. We will comment on relevant proton and neutron shells again when we deal with orbital-angular-momentum quantization of direction vectors of these shells.

Figure 3 represents the most probable forms of the 1p and the 1d2s nuclear shells accommodating 6 and 12 neutrons or protons, respectively. The vectors shown in the figure stand **identically** (that is, precisely to any order of accuracy) for the orbital-angular-momentum quantization of directions with quantum numbers $\ell = 1$ and 2, respectively and $-\ell \leq m \leq \ell$ [3]. This should happen any way since the most probable form of each of the 1p and 1d2s nuclear shells represented in Fig. 3 is also one out of the infinite number of instantaneous nuclear forms these shells could have and as such all nuclear properties should be valid and should have a geometrical representation. Specifically, the quantization of direction vectors of orbital-angular-momentum with quantum numbers ℓ and m should result as property of the symmetries of the relevant polyhedron for each shell. Indeed, these

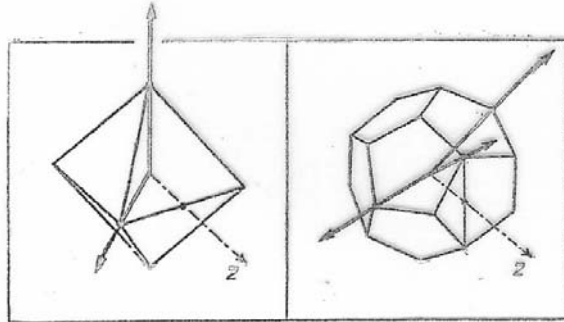

Fig.3. Most probable forms of the 1p and the 1d2s nucleon shells, and the corresponding orbital-angular-momentum quantization of direction vectors for $\ell = 1, -1 \leq m \leq 1$ and $\ell = 2, -2 \leq m \leq 2$.

orbital-angular-momentum quantization of direction vectors for the 1p shell (which is represented by the octahedron in Fig. 3) pass through the polyhedral vertices (or through the middles of faces of the reciprocal shell which has a cube as its most probable form.). Also, the orbital-angular-momentum quantization of direction vectors for the 1d2s shell (which is represented by the dodecahedron in Fig. 3) also pass through the polyhedral vertices (or through the middles of faces of the reciprocal shell which has an icosahedron as its most probable form.). These orbital-angular-momentum quantization of direction vectors with respect to the shown quantization axis z for each shell (which z axes coincide and become a common quantization axis for both shells when the two relevant polyhedra are superimposed with common center and orientations as shown.) form **identically** the angles

$${}_n\theta_\ell^m = \cos^{-1} m / [\sqrt{\ell(\ell + 1)}]. \quad (14)$$

In Fig. 4 it is shown that similar properties to those represented in Fig. 3 are also valid for all orbital angular momenta with quantum numbers $\ell = 1- 6$ and $-\ell \leq m \leq \ell$ with respect to the polyhedra in the first three rows of the figure. In each block of the fourth row the relation between the polyhedra in the same column (rows 1-3) is given [3]. The polyhedra represented in Fig. 4 have symmetries in relation to orbital-angular-momentum quantization of direction vectors which are included in the symmetries of the polyhedra standing for the most probable forms of nuclear shells shown in the next figure.

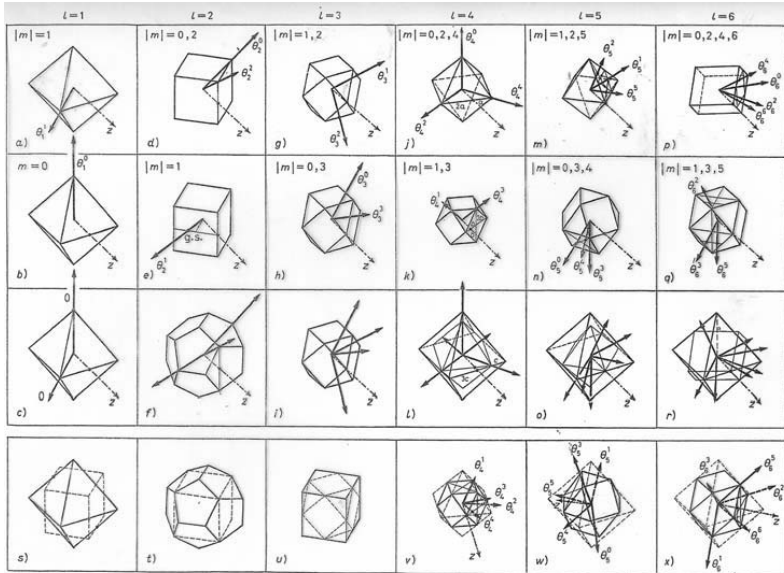

Fig.4. Angular-momentum quantization of direction vectors in relation to the polyhedra shown

In Fig. 5 all polyhedra representing the most probable forms of all nuclear shells involved up to Pb are given and are considered superimposed with a common center and orientations as shown [4]. At the bottom of each block of the figure the order of a proton (Z) or of a neutron (N) shell is given (i.e., Z1, N2 etc). In the next row inside parentheses the number of vertices for the relevant polyhedron, inside brackets the cumulative number of vertices of all previous proton or neutron polyhedra and that polyhedron, and the radius of that polyhedron (obtained by packing the shells themselves, and by considering the average size of a proton and of a neutron to be 0.860 fm and 0.974 fm, respectively) are also given. More details are not given here for this figure, but they are extensively included in [4], where also an explanation for the reason why some of Leech-polyhedra are taken as most probable forms of proton shells and some of them as most probable forms. of neutron shells.

In this figure we consider that all nucleons **simultaneously** reside at their most probable positions, which coincide with the vertices of the known polyhedral shells. Such a structure resembles a crystal structure, but it is not, since it is not permanent. It represents only a momentary (the most probable) structure which, of course, reappears **periodically** due to the fact that the orbital-angular-momentum quantization of direction vectors are axes of symmetry of the relevant polyhedra. The same property makes Fig.5 as a whole to have a meaning as a pictorial

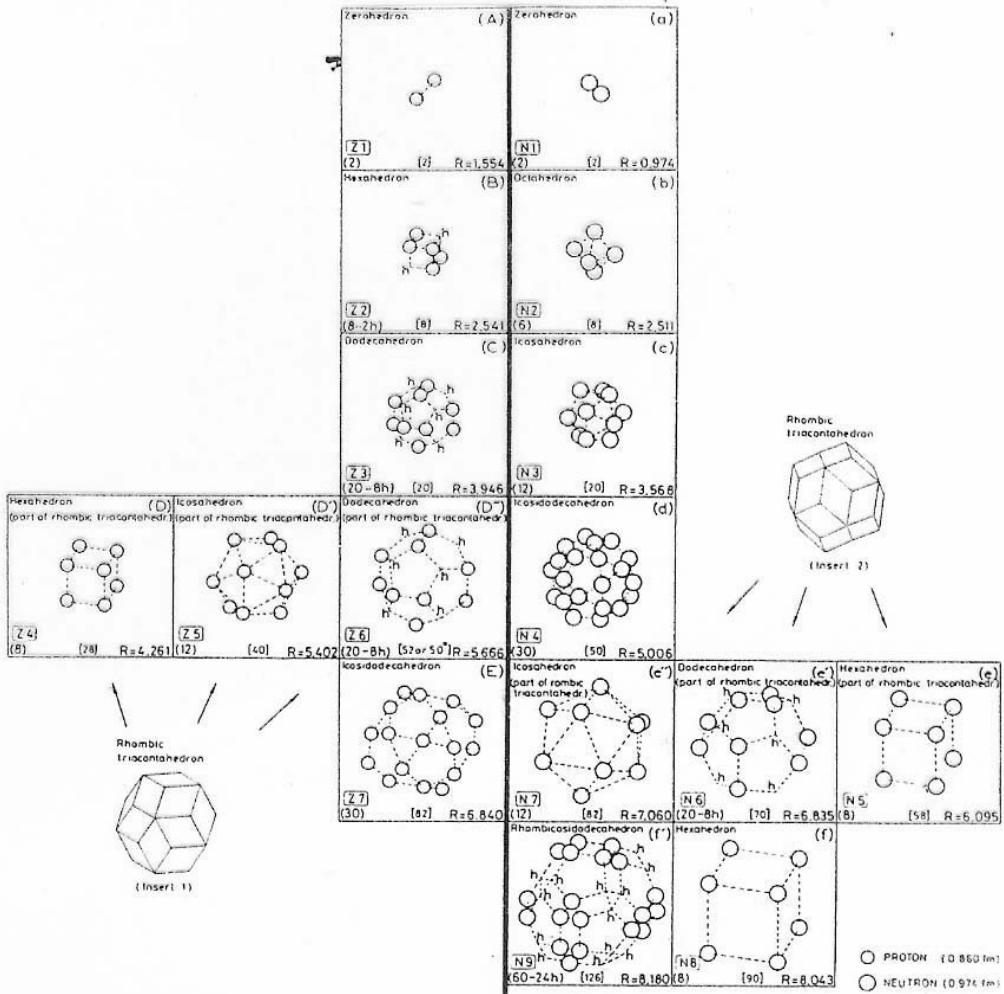

Fig.5. Pictorial average nuclear structure of all closed shells up to ^{208}Pb . The numbers in brackets given at the bottom of the blocks of the figure coincide with the experimentally known magic and semi-magic numbers.

representation of the shell structure of a nucleus. It is very interesting to notice that the cumulative numbers in brackets of Fig. 5 (mentioned earlier) are identical to the nuclear magic and semi-magic numbers 2, 8, 20, 28, 40, 50, 70, 82, and 126. Thus, the magic numbers here are strictly the result of the fermionic nature of identical nucleons and not the result of a strong spin orbit coupling as assumed in the conventional shell model. It is in support of the present explanation of nuclear magic numbers the fact that identical magic numbers appear in certain cases of atomic clusters [5-7] where a strong spin orbit coupling certainly does not exist. There, apparent fermions are the decoupled electrons, but also neutral atoms in the cluster if the number of the electrons in an atom is an odd number, or the positive ions in the core of the cluster after an odd number of electrons has been decoupled from each neutral atom with an even number of electrons. The neutral atoms and the positive ions

previously described behave like heavy fermions and obey all equations of section 2 here. Thus, it is expected this type of fermions to form polyhedral shells of Leech type and the decoupled electrons to behave like electrons in a giant atom where the polyhedra of positive ions play the role of the core in this giant atom. The common ground of these seemingly irrelevant structures is that they refer to **mesoscopic** physics of fermions.

Now, having this momentary (most probable) shell structure of a nucleus, we can proceed either in a semiclassical way by employing a two-body potential, e.g., that of Eq. (15) [8]

$$V(r_{ij}) = V_R e^{-\mu_R r_{ij}} / r_{ij} - V_A e^{-\mu_A r_{ij}} / r_{ij}, \quad (15)$$

or we can proceed in a purely quantum mechanical way by deriving the proper $\hbar\omega$ value for each nuclear shell by employing Eq.(16), where the value of $\langle r_i^2 \rangle^{1/2}$ for each shell is taken [9] from Fig.5, as explained earlier

$$\hbar\omega_i = \hbar^2(n + 3/2) / [m \langle r_i^2 \rangle]. \quad (16)$$

Thus, due to the antisymmetrization requirement of the wave function for the many nucleons in a closed shell nucleus, we first arrive at the distribution of maxima of this wave function and the size of the corresponding shell, then going backwards we can write the wave function itself.

5. Conclusions

Starting with the simplest possible problem of two identical fermions in a square-well potential with infinite walls, we arrive at the conclusion that identical fermions in a common potential behave as if a repulsive force (of unknown nature) is acting among the particles [1]. Furthermore, we take advantage of this conclusion together with a mathematical paper [2] dealing with identical repulsive particles on a sphere like protons and neutrons in a nuclear shell, and we come to the conclusion that only a certain number of particles can be accommodated in a shell which has as its most probable form that of a regular polyhedron or its derivative polyhedra [2]. The same paper is used to examine the case where two kinds of fermions, like protons and neutrons in a nucleus, are in a common potential. In this case the proton and the relevant neutron shells have as their most probable forms reciprocal polyhedra (i.e., polyhedra where the vertices of the one are the middle of faces of the other) [2]).

A proper superposition of such polyhedral shells leads to a pictorial shell- structure of a close-shell nucleus [4]. Each time a polyhedral shell (of neutrons or protons) is completed, a magic or semi-magic number appears, i.e., the sum of vertices of all proton or neutron previous polyhedra and that polyhedron is equal to one of the numbers 2, 8, 20, 28, 40, 50, 70, 82, and 126. In addition, by assuming that the average size of a proton and of a neutron has the value 0.860 fm and 0.974 fm, respectively, and by further considering that the above polyhedral shells are superimposed with common center and in contact with each other, we arrive at the average structure and the size of all closed-shell nuclei [4].

By utilizing this structure we can proceed in calculations of nuclear observables either in a semi-classical way taking a two-fermion potential like that of Eq. (15) or in a purely quantum mechanical way estimating the $\hbar\omega$ for each shell from Eq. (16)

Finally, making a long story short, we can say that the fermionic nature of protons and neutrons alone leads to the distribution of maxima of probability of the antisymmetrized wave function of protons and neutrons on the vertices of equilibrium polyhedra [2] and to the appearance of magic numbers [4]. The average structure thus derived is that represented in Fig. 5 and could serve as a nuclear laboratory for calculations and a pictorial explanation of nuclear observables and nuclear phenomena.

References

- [1] C. W. Sherwin, *Introduction to Quantum Mechanics*, Holt, Rinehart and Winston, New York (1959), p 205.
- [2] J. Leech, *Mathematical Gazette* 41 (1957) 81.
- [3] G.S. Anagnostatos, *Lettere al Nuovo Cimento* 29 (1980) 188.
- [4] G.S. Anagnostatos, *International J. of Theoretical Physics* 24 (1985) 579.
- [5] G.S. Anagnostatos, *Phys. Lett. A* 128 (1988) 266.
- [6] G.S. Anagnostatos, *Phys. Lett. A* 154 (1991) 169.
- [7] G.S. Anagnostatos, *Phys. Lett. A* 157 (1991) 65.
- [8] G.S. Anagnostatos and C.N. Panos, *Phys. Rev. C* 26 (1982) 260.
- [9] G.S. Anagnostatos, *Can. J. Phys.* 70 (1992) 361.