

HNPS Advances in Nuclear Physics

Vol 17 (2009)

HNPS2009



Underground Low Flux Neutron Background Measurements in LSM Using a Large Volume (1m3) Spherical Proportional Counter

I. Savvidis

doi: [10.12681/hnps.2570](https://doi.org/10.12681/hnps.2570)

To cite this article:

Savvidis, I. (2019). Underground Low Flux Neutron Background Measurements in LSM Using a Large Volume (1m3) Spherical Proportional Counter. *HNPS Advances in Nuclear Physics*, 17, 43–46. <https://doi.org/10.12681/hnps.2570>

Underground Low Flux Neutron Background Measurements in LSM Using a Large Volume (1m³) Spherical Proportional Counter

I Savvidis¹, I Giomataris², E Bougamont², I Irastorza⁴, S Aune², M Chapelier², Ph Charvin², P Colas², J Derre², E Ferrer², G Gerbier², M Gros², P Mangier², XF Navick², P Salin⁵, J D Vergados⁶ and M Zampalo³

1 : Aristotle University of Thessaloniki, Greece

2 : IRFU, Centre d'études de Saclay, 91191 Gif sur Yvette CEDEX, France

3. LSM, Laboratoire Souterrain de Modane, France

4: University of Saragoza, Spain

5 : LSBB, France

6: University of Ioannina, Greece

Abstract: A large volume (1m³) spherical proportional counter has been developed at CEA/Saclay, for low flux neutron measurements. The high voltage is applied to a small sphere 15mm in diameter, located in the center of the counter and the wall of the counter is grounded. Neutrons can be measured successfully, with high sensitivity, using ³He gas in the detector. The proton and tritium energy deposition in the drift gaseous volume, from the reaction ³He(n,p)³H, can provide the neutron spectra from thermal neutrons up to several MeV.

The detector has been installed in the underground laboratory in Modane (LSM) to measure the neutron background. The sphere has been filled with gas mixture of Ar + 2% CH₄ + 3gr He-3, at 275 mbar. The thermal neutron peak is well separated from the cosmic ray and gamma background, permitting of neutron flux calculation. Other potential applications requiring large volume of about 10 m in radius are described in detail in reference

1. Introduction

The investigation on the large volume spherical proportional counter resulted in the development of a new neutron detector, based on the ³He(n,p)³H reaction[1]. The low background of the detector and the possibility to separate the γ ray pulses from the protons and alpha particle pulses increases the sensitivity on the neutron detection. The detector can successfully measure very low neutron fluxes

(10⁻⁶n/cm²/s, for thermal neutrons), providing the neutron energy spectrum from thermal up to several MeV at ground and underground level.

The large spherical geometry drift (1m³), the good energy resolution (<2% FWHM with alpha particles at 5.5 MeV) and the simple read out (one channel reading) are some of the advantages of the detector. Other potential applications of this device requiring large volume are described in detail in reference [2,3,4,5,6,7].

2. The detector

The detector consist of a copper sphere, 1.3 m in diameter and 6mm thick (figure 1). The spherical vessel is well pumped (up to 10⁻⁸ mbar) and then is filled with a gas mixture at a pressure from several hundreds of mbars up to 5 bars. Out gassing in the order of 10⁻⁹ mbars/s is necessary for the amplification stability, because the present of the O₂ in the drift volume changes the detector characteristics.

A small stainless ball of 14 centimeter in diameter fixed in the center of the spherical vessel by a stainless steel rod (figure 2), acts as an electrode with positive high voltage and as a proportional amplification counter. The detector was operated with positive bias applied to the anode (inner sphere) while the cathode (external sphere) remained at ground potential. A high voltage capacitor was decoupling the high voltage cable to protect the sensitive preamplifier.

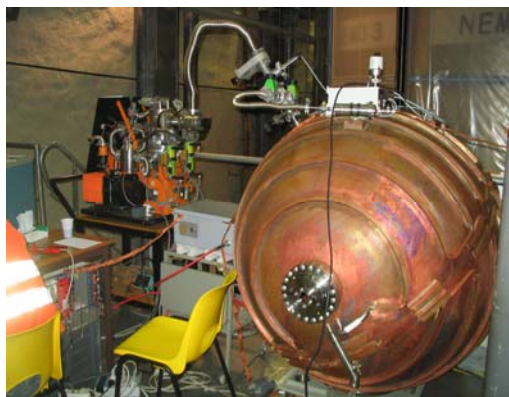

Figure 1. A photograph of the spherical vessel

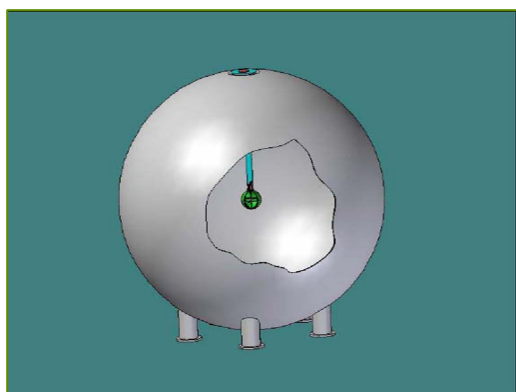

Figure 2. Sketch of the detector.

3. The electric field

The electric field in the drift volume plays a very important role for the proportionality and the energy resolution of the detector. The ideal detector is a spherical capacitor with perfect radial symmetric electric field. In a real implementation of the spherical TPC concept, the ideal spherical symmetry is broken by the rod that supports the central electrode and that necessarily connects it to the front-end electronics, placed outside,

to amplify and read the signals. In figure 3 the equipotential lines are plot for this simplest geometry, showing how the presence of this rod makes the electric field to be far from spherically symmetric. It means that the amplification depends on the direction and the position of the track of a charge particle in the drift volume and makes impossible the energy resolution.

To solve the problem of field distortion due to voltage anode electrode, a cylinder around the high voltage rod, placed at 4 mm away from the central sphere and powered with an independent voltage V_2 (which can be zero, i.e., at ground). The equipotential lines for the described “corrected” configuration are shown in figure 4.

Energetic charged particles, x-rays, or gamma rays or even neutrons entering the detector strip electrons from the gas atoms to produce positively charged ions and negatively charged electrons. The electric field created across the electrodes drifts the electrons to the positive electrode. Near the inner anode sphere the electric field is high enough and electrons gain enough energy to ionize more gas atoms, a process that produces more electrons. Typical gases at atmospheric pressure required field strength on the order 10kV/cm to produce the avalanche of secondary electrons around the small anode ball. The avalanche is produced at a few mms distance from the anode and the positive ions drifting toward the cathode are inducing a pulse to the charge preamplifier. Since the avalanche takes place near the small ball and the electrons are attracted to it the positive ions travel a much greater distance. Therefore the induced pulse to the preamplifier is mainly due the ion movement; electrons produced during avalanche process have a negligible contribution to the signal.

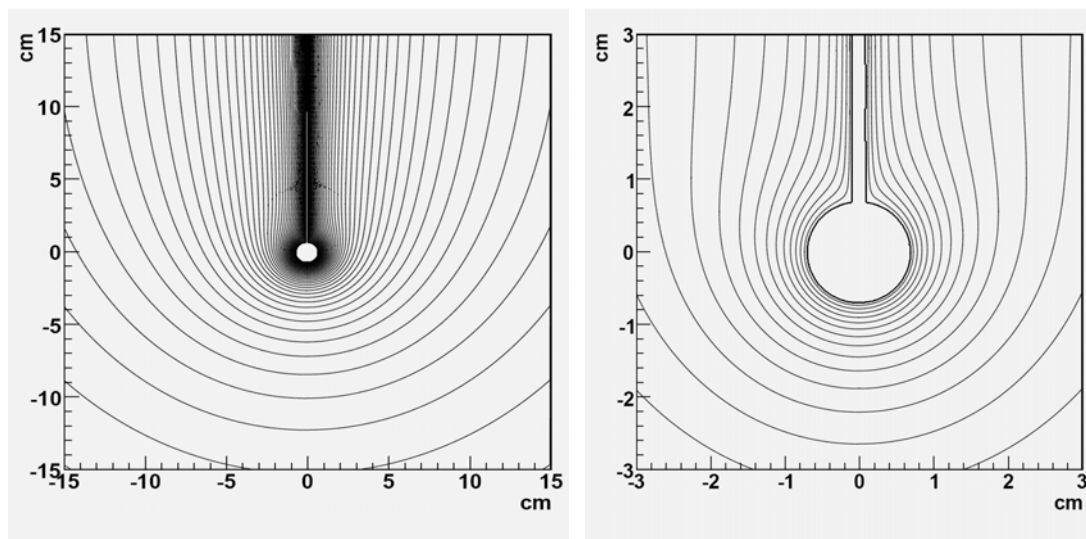

Figure 3. The equipotential lines around the 14 mm sphere without any correction.

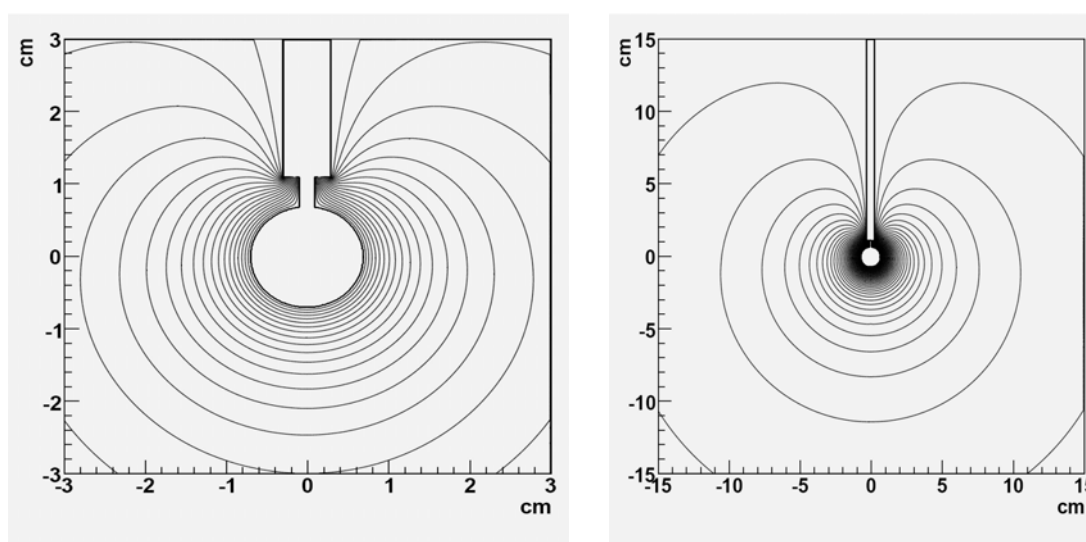

Figure 4. Electrostatic configuration for the readout electrode, with the "corrector"

4. The energy resolution

The energy resolution of the detector has been tested using ^{222}Rn gas and detecting the alpha particles from ^{222}Rn and ^{222}Rn daughters. Since the ^{222}Rn gas covers homogeneously all the drift volume of the detector, we have alpha emission in every direction and in all the positions of the detector. The gas mixture consists of Ar (98%) and CH₄(2%) at pressures, from 150 mbars up

to 1 bar. The high voltage varies from 1.5 kV up to 5 kV depending on the gas pressure. In figure 5 is shown the peaks observed from a ^{222}Rn radioactive source. From left to right we observe the ^{222}Rn peak at 5.5 MeV, the ^{218}Po and ^{214}Po at 6.0 MeV and 7.7 MeV respectively. The energy resolution was 2% FWHM at 200 mbar gas pressure and 2.8 kV High Voltage.

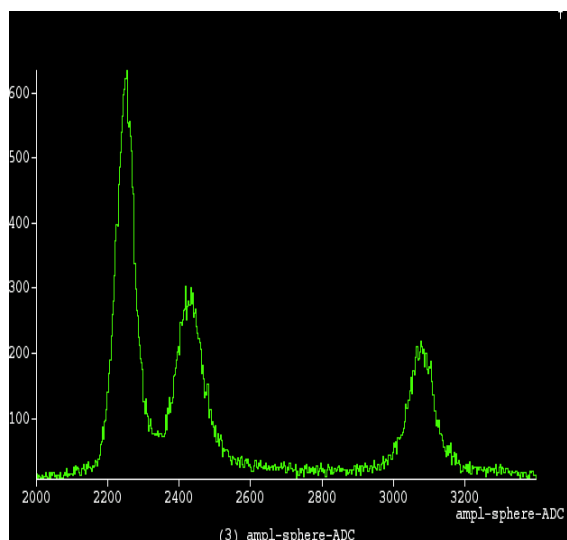

Figure 5. The peaks observed from a ^{222}Rn radioactive source. From left to right we observe the ^{222}Rn peak at 5.5 MeV, the ^{218}Po and ^{214}Po at 6.0 MeV and 7.7 MeV respectively.

5. The thermal neutron flux in the LSM

In the present work we have been used the ^3He gas as converter for thermal and fast neutron detection up to several MeV. Neutrons interact with ^3He as follows, $n+^3\text{He}\rightarrow p+^3\text{H}+765\text{ keV}$. The signal is the sum of the p and ^3H energy deposition in the drift volume and depends on the neutron energy. In the case of thermal neutrons we measure one peak 765 keV and for the fast neutrons the energy peak is $E_n + 765\text{ keV}$, where E_n is the fast neutron energy.

The detector has been installed in the LSM, to measure the underground neutron flux. The gas mixture was Ar +2% CH₄ at p=280 mbar with 3 gr of He-3. Thermal neutron capture rate was 0.0048 evts/s = 417 evts/d and the thermal neutron flux was $\Phi_{\text{th}}=1.9\cdot 10^{-6}\text{ n/cm}^2/\text{s}$. In the figure 6 is shown the thermal neutron peak after rise time cut.

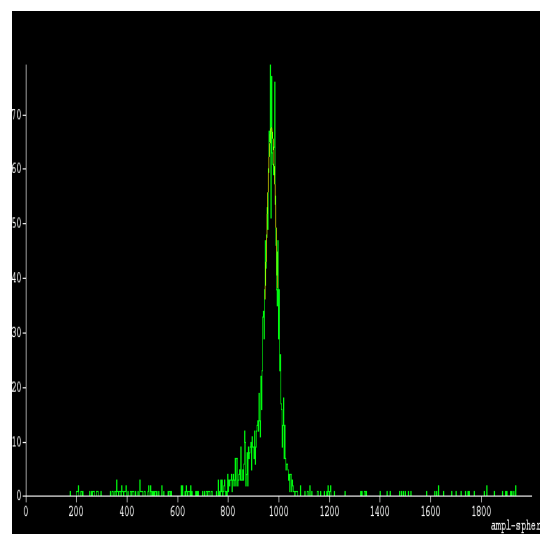

Figure 6. The thermal neutron peak after rise time cut.

6. Conclusions

The spherical proportional counter is a high sensitivity neutron detector. The sensor is stable for long time measurements and the decrease in gain is small ($\approx 0.2\%$ per day). The detector can measure low fluxes of the underground thermal neutrons and the seasonal variation of the flux.

REFERENCES

- [1] I. Giomataris et al., JINST 3:P09007,2008.
- [2] I. Giomataris and J.D. Vergados, Nucl.Instrum.Meth.A530:330-358,2004
- [3] I. Giomataris *et al.* Nucl.Phys.Proc.Suppl.150:208-213,2006.
- [4] S. Aune *et al.*, AIP Conf.Proc.785:110-118,2005.
- [5] I. Giomataris and J.D. Vergados, Phys.Lett.B634:23-29,2006.
- [6] J. D. Vergados et al., Phys.Rev.D79:113001,2009.
- [7] A. Dedes et al., arXiv:0907.0758