

HNPS Advances in Nuclear Physics

Vol 21 (2013)

HNPS2013

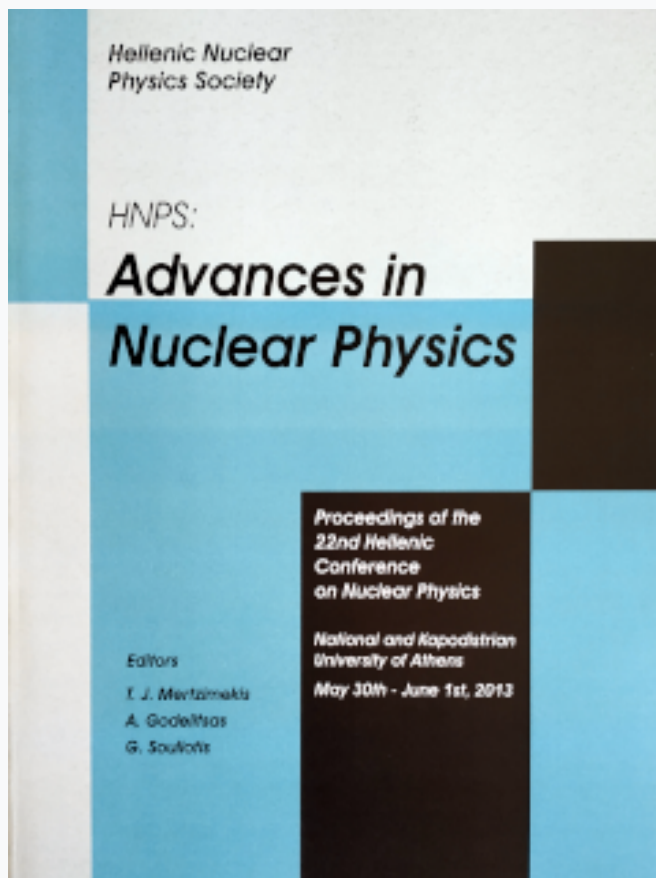

Construction of a High-Resolution Mobile γ -Camera System for Mammography Study

M. Zioga, M. Kontos, D. Maintas, M. Mikeli, A.-N. Rapsomanikis, E. Stiliaris

doi: [10.12681/hnps.2013](https://doi.org/10.12681/hnps.2013)

To cite this article:

Zioga, M., Kontos, M., Maintas, D., Mikeli, M., Rapsomanikis, A.-N., & Stiliaris, E. (2013). Construction of a High-Resolution Mobile γ -Camera System for Mammography Study. *HNPS Advances in Nuclear Physics*, 21, 110-114. <https://doi.org/10.12681/hnps.2013>

Construction of a High-Resolution Mobile γ -Camera System for Mammography Study

M. Zioga^a, M. Kontos^b, D. Maintas^c, M. Mikeli^a, A.-N. Rapsomanikis^a, E. Stiliaris^{a,d,1}

^a*Department of Physics, National & Kapodistrian University of Athens, GR-15771 Athens, Greece*

^b*LAIKON Hospital, Medical School, National & Kapodistrian University of Athens, Athens, Greece*

^c*Institute of Isotopic Studies, Medical Center of Athens, Athens, Greece*

^d*Institute of Accelerating Systems & Applications (IASA), GR-10024 Athens, Greece*

Abstract

A small-field portable γ -Camera system based on a Position Sensitive Photomultiplier Tube (PSPMT) has been recently developed in our Lab. This γ -Camera system has been characterized on planar and tomographic level and exhibits high efficiency and resolution (0.95 ± 0.5 mm spatial resolution on planar imaging and $0.20\mu Ci$ sensitivity on a tomographic level). Even though a portable γ -Camera system has many advantages, it shows a strong dependence from the operators hand stability which greatly affects the quality of the acquired image. To overcome these circumstances a need for a motion correction technique arises. In the present work, a simple a low cost solution to overcome this stability problem by means of commercially available equipment is proposed. It is based on the Nintendo's Wii Remote sensors, a small handheld device which can be easily coupled to the portable camera. It comprises both, a 3D-accelerometer which reports the three detected components of the gravity acceleration and an infrared sensor for a fix-point distance evaluation. The Wii Remote sensors device is wireless and operates with modern communication protocols (Bluetooth). Based on the received accelerometer and infrared-sensor data by a DAQ system developed on the LabVIEW environment, the γ -Cameras DAQ system is capable to store all the primary parameters on an event-by-event basis and to perform the necessary motion correction in real time. Some typical image correction results are presented in the current work.

Keywords: Portable γ -Camera, Position Sensitive PhotoMultiplier Tube PSPMT, Motion Correction

1. Introduction

In Nuclear Medicine a general purpose γ -Camera device is commonly used. Since its introduction, it has become a standard choice for clinical *in vivo* tests. It provides information about the distribution of a radiotracer administered to a patient allowing noninvasive measurement of physiological functions. A general purpose γ -Camera shows disadvantages when used for imaging of small organs, such as breast, thyroid or sentinel lymph node, due to the large field of view and volume occupied, which affects the spatial resolution of the obtained images. For such small organ studies, the large detector of a standard commercial γ -Camera cannot be placed close to the organ of interest, accepting background activity from other neighbor organs and allowing only certain planar projections to be imaged. These factors imply that the general purpose γ -Cameras have non optimal spatial resolution and poor image contrast regarding the small organ imaging and also they can't be used in Operating Rooms and Intensive Care Rooms. For all the previous reasons, a dedicated, small field, high resolution portable γ -Camera for clinical use must be manufactured.

¹Corresponding author: stiliaris@phys.uoa.gr

2. System Description

In the past years, in our laboratory a prototype small field γ -Camera system based on the R2486 (HAMAMATSU) Position Sensitive PhotoMultiplier Tube has been developed [1–3].

2.1. The Small γ -Camera System

This small field (50 mm effective field of view) γ -Camera system utilizes the resistive chain technique in order to reduce the 16-X and 16-Y multianode wire-system to only four signals. The whole system comprises a parallel-hole Pb-collimator of hexagonal type, with a total area of $60 \times 60 \text{ mm}^2$ and a 4 mm thick CsI(Tl) pixelated scintillation crystal. Due to the applied signal reduction technique (shown in Figure 1), the Data Acquisition (DAQ) system consists of a 4-channel fast PCI-1714 Analog-to-Digital Converter (ADC) [4]. After several experimental studies with ^{99m}Tc phantoms the system has been recently characterized on both planar and tomographic level and exhibits high efficiency.

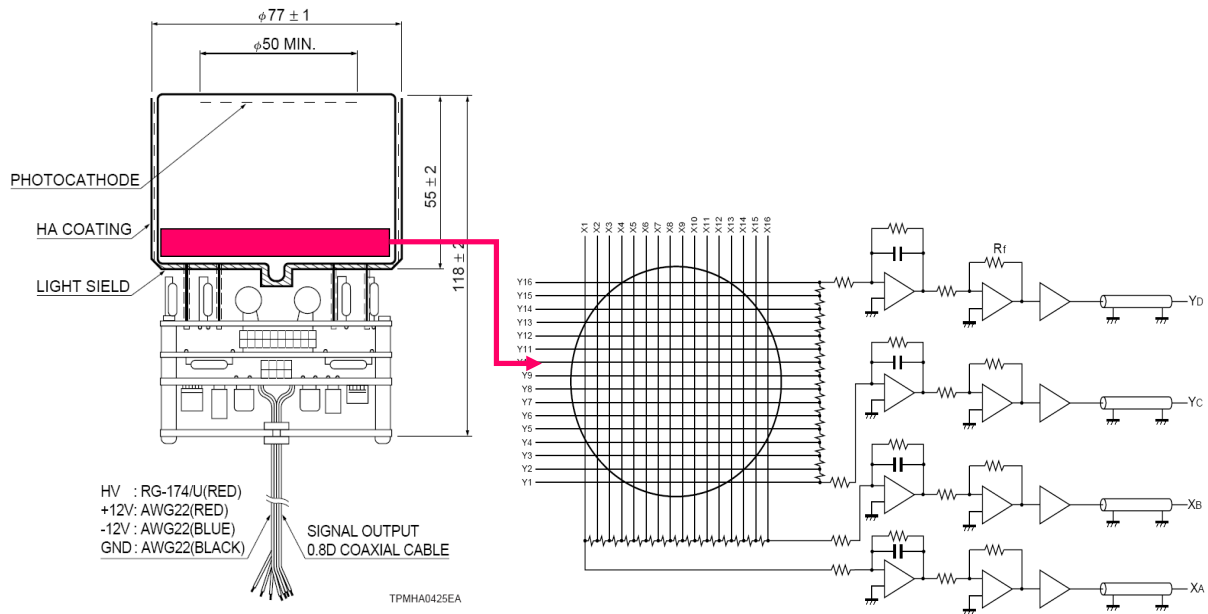

Figure 1: Based on the Resistive Chain Technique the 16-X and 16-Y multianode wire-system is reduced to only four signals.

The main characteristics of this system are:

- 1 Resolution on a planar level: $\langle \sigma_x \rangle = \{0.95 \pm 0.05\} \text{ mm}$ and $\langle \sigma_y \rangle = \{1.07 \pm 0.07\} \text{ mm}$
- 2 Resolution on a tomographic level: 2 mm in both X- and Y-Axis
- 3 Sensitivity on a tomographic level: Minimum volume which can be detected $V=0.080 \text{ cm}^3$ (which corresponds to $20 \mu\text{Ci}$ activity for a tracer solution of special activity 0.25 mCi/cm^3).

2.2. Clinical Adjustments

In order to use this portable small field γ -Camera in a clinical environment, several adjustments must take place.

- A proper shielding is necessary to ensure the light isolation of the detector's head-system. A gun-like casing will be ideal for a comfortable operation during the surgical procedures.

- A proper DC-to-DC converter must be used to provide high voltage to the isolated head system, allowing a safe connection with the rest of the low voltage system's wiring.
- Orientation of the Camera is crucial to the operator, thus a 3D-accelerometer will be encased in the head probe providing the necessary information for an automatic mapping orientation of the projected image. The γ -Camera will be connected via a USB portal to a computer with a DAQ system, operating in the previously described digitization mode (4-channel ADC).

3. Camera's Motion Correction

Even though a Small Field Portable γ -Camera has many advantages, it shows a strong dependence from the operators hand stability which affects greatly the quality of the acquired image. To overcome this predicament a need for a motion correction technique arises. For this motion correction technique in addition to the planar position data also acceleration data are needed.

In order to acquire all the necessary information the Nintendo's Wii Remote is coupled to the portable γ -Camera System so a calculation of its movement to be possible. The Wii Remote is the primary controller for Nintendo's Wii console; it is also low cost and commercially available and additionally has the ability to sense acceleration along three axes through the use of the ADXL330 accelerometer [5]. The Wii Remote ADXL330 reports acceleration in the device's three directions g_x, g_y, g_z , expressed in units of the earth's gravity g with a resolution of 8 bits per axis and a 100 Hz update rate. The acquired acceleration data are transmitted to the DAQ System via Bluetooth protocol.

4. DAQ System

The Data Acquisition System of this portable camera has been developed on the LabVIEW environment. In addition to the four primary signals from the photomultiplier resistive chain (SX_1, SX_2, SY_1, SY_2) the three g -components (g_x, g_y, g_z) and the planar offset X_{off} and Y_{off} from the Wii Remote device are recorded. The flow diagram of this process is depicted in Figure 2.

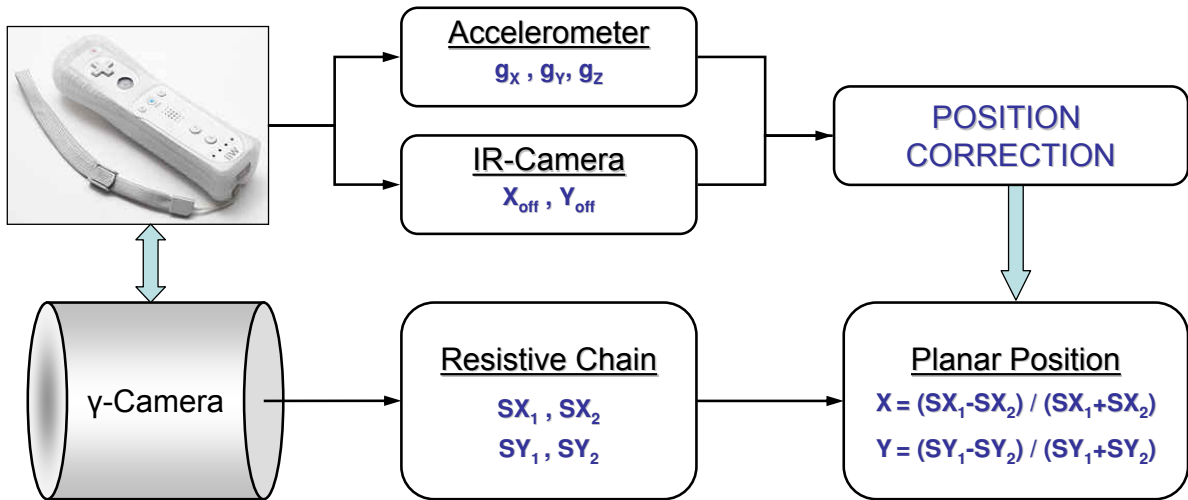

Figure 2: Flow diagram of DAQ recorded parameters during operation of the portable γ -Camera System.

The acquired data from the γ -Camera are

$$X = \frac{SX_1 - SX_2}{SX_1 + SX_2} \quad Y = \frac{SY_1 - SY_2}{SY_1 + SY_2} \quad (1)$$

$$\begin{pmatrix} g_x \\ g_y \\ g_z \end{pmatrix} = \begin{pmatrix} \cos\psi\cos\phi - \cos\theta\sin\phi\sin\psi & \cos\psi\sin\phi + \cos\theta\cos\phi\sin\psi & \sin\theta\sin\psi \\ -\sin\psi\cos\phi - \cos\theta\sin\phi\cos\psi & -\sin\psi\sin\phi + \cos\theta\cos\phi\cos\psi & \sin\theta\cos\psi \\ \sin\theta\sin\psi & -\sin\theta\cos\phi & \cos\theta \end{pmatrix} \times \begin{pmatrix} 0 \\ 0 \\ 1 \end{pmatrix} \quad (2)$$

Based on the definition of the Euler angles (Equation 2) the rotation θ and ϕ angles of the Camera can be calculated for any detected event. So the angle θ is

$$\theta = \arccos g_x \quad (3)$$

and the corrected coordinates are:

$$X_c = X\cos\theta - Y\sin\theta \quad (4)$$

$$Y_c = X\sin\theta + Y\cos\theta \quad (5)$$

These angles, together with the planar offsets (X_{off}, Y_{off}) recorded by the infrared-camera, can be used to correct the position of the incident γ -photon on the planar image.

5. Experimental Data

The γ -Camera System was rotated along an eccentric point inside the field of view using a ^{137}Cs point source. The source was placed 10 cm away from the Camera and for every angle 100.000 events were recorded. Applying the event-by-event correction of the Camera's movements the quality of the acquired image is greatly improved as shows Figure 3.

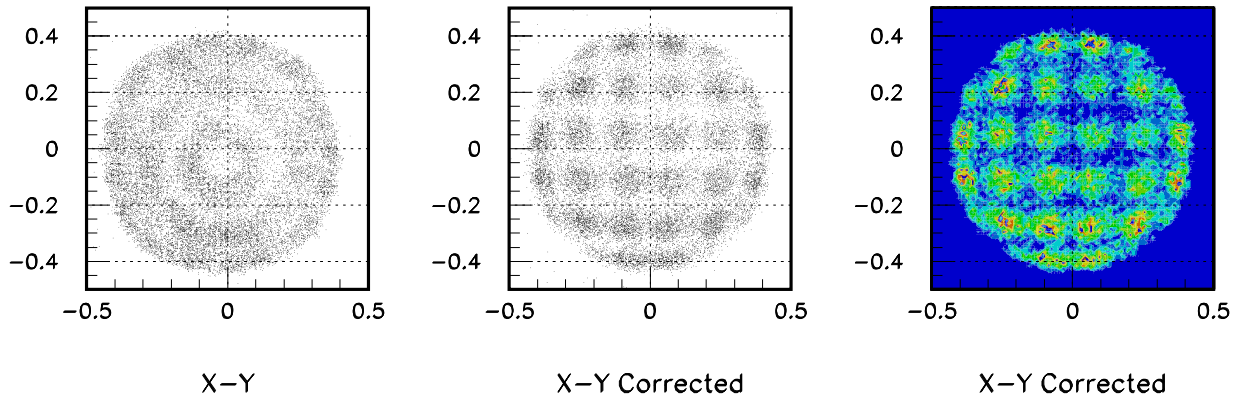

Figure 3: A typical planar image taken with a uniform source and a hole-screen in front of the moving γ -Camera system. *Left:* Uncorrected planar image. *Center:* Motion corrected image with the developed procedure. *Right:* Contour plot of the motion corrected image.

6. Summary

In summary, the Wii-Remote, a simple and low cost construction has been mechanically coupled to the small field handy γ -Camera system, which can potentially correct on an event-by-event basis any movement or rotation. Based on the build-in 3g-accelerometer and the information captured by the infra-red camera the position information can be online reconstructed. Early experimentations show promising results.

References

- [1] M. Mikeli, D. Thanasas and E. Stiliaris: "Collimator Study of a γ -Camera System using GATE", IEEE Nuclear Science Symposium and Medical Imaging Conference Record M13-360 (2009) 3931-3935.
- [2] D. Thanasas *et al.*: "A Correction Method of the Spatial Distortion in Planar Images from γ -Camera Systems", Journal of Instrumentation **4** (2009) P06012.
- [3] S. Angeli and E. Stiliaris: "An Accelerated Algebraic Reconstruction Technique based on the Newton-Raphson Scheme", IEEE Nuclear Science Symposium and Medical Imaging Conference Record M09-323 (2009) 3382-3387.
- [4] V. Spanoudaki *et al.*: "Design and Development of a Position-Sensitive γ -Camera for SPECT Imaging based on PCI Electronics", Nuclear Instruments and Methods **A 527** (2004) 151-156.
- [5] Chadwick A. Wingrave *et al.*: "The Wiimote and Beyond: Spatially Convenient Devices for 3D User Interfaces", IEEE Computer Graphics and Applications, March-April 2010, 71.